

CURNUTT Shocks, Romic Shocks

FOX Shocks RL

CURNUTT Shocks 5 inch wheel travel

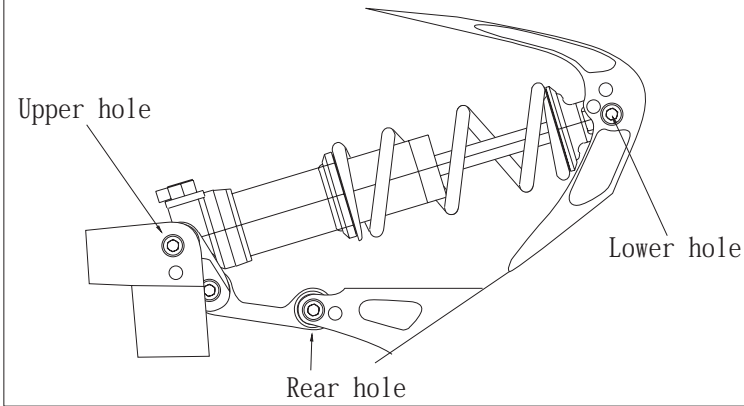

FOX Shocks 5 inch wheel travel

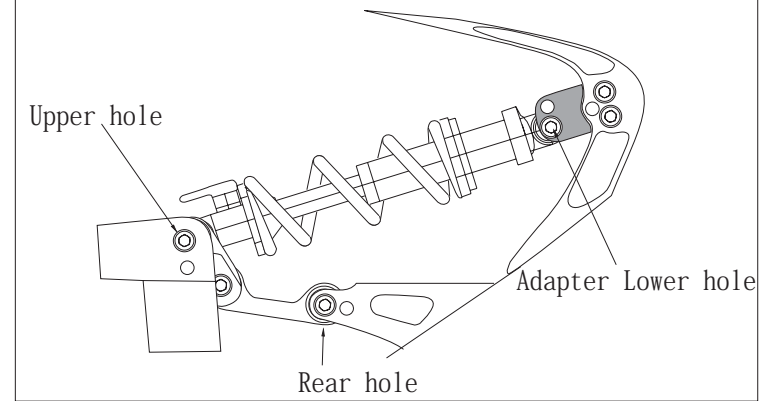

CURNUTT Shocks 6 inch wheel travel

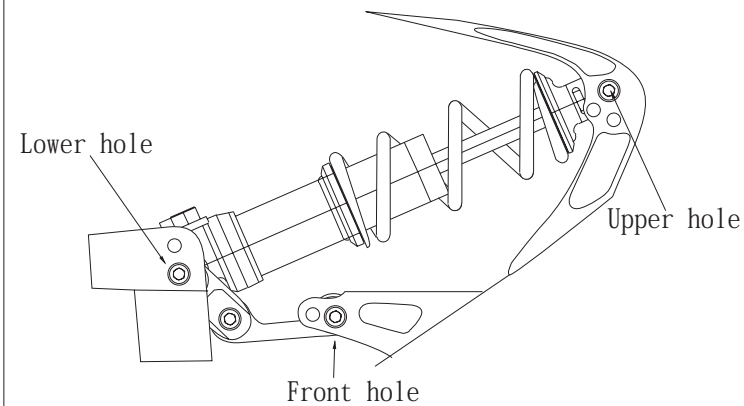

FOX Shocks 6 inch wheel travel

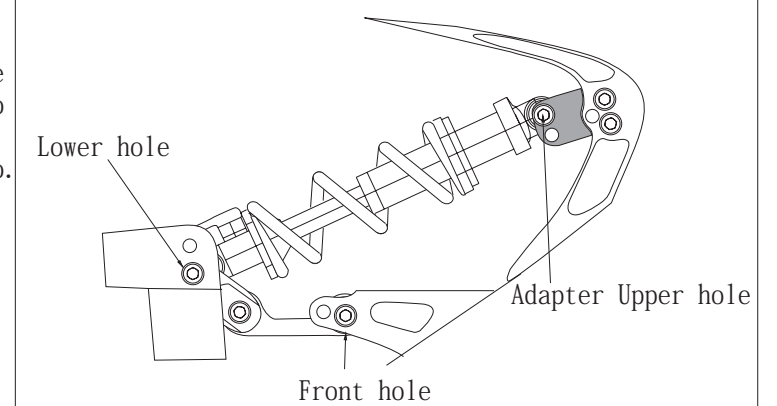

When the shock is moved into the this position, it is recommended to increase the Spring rate by at least 50 pounds to compensate for The increased leverage ratio.