

These rates are for the DHS Mono ONLY. Shocks ridden under sprung will not be considered warranty when brought in for repair due to excessive bottoming. Excessive bottoming will ruin the internal components of the shock and warranty will not be considered. Foes is easily able to tell what the shock has been through when we perform service. It is important for you, the RIDER, to keep track of your equipment.

Here are some items to make sure are correct for proper working of your Curnutt XTD Shock;

Air pressure should be checked before every ride & should be between 65psi-100psi

Sag should be about 1"

Spring Preload should not exceed 4 1/2 complete turns

Reducers & Bushings do not have a exact wear pattern, these items wear different with every rider and therefore need to be checked regularly for wear. Worn out bushings and reducers will put loads on the shock which could cause the shock to perform improperly.

If adjustments, spring rate, and air pressure are CORRECT according to Foes specs, the XTD shock should not bottom out. If bottoming occurs on a consistent basis, and the settings are correct than something is wrong internally and the shock must be returned to Foes for service.

SPRING	RIDER WEIGHT WITH GEAR
300	130-145
350	146-160
400	161-175
450	176-190
500	191-210
550	211-230

MAXIMUM RIDER WEIGHT
230LBS.

All XTD Shocks are built by hand under the supervision of Curnutt Shocks Inc., each shock is tested and checked for problems before it leaves Foes. There is no reason for any XTD shock to not perform correctly once you have read these instructions and all settings are set correctly. Curnutt XTD Shocks have a 1 year warranty against manufactures defects; shocks in question for warranty status will be determined by Foes at the time of inspection. This manual should accompany every XTD shock!

© 2004 Foes Fabrications, Incorporated.

Manual content by Charlie Curnutt, Jr., Brent Foes, Rich Cleveland, and Eric Butler

Now go ride your bike.



Foes DHS Mono Owner's Manual 2004-2005

**It is your responsibility to read this manual
to fully understand your warranty on this**

Included with every DHS-Mono, the Hadley made rear hub is one of the best money can buy. Here are the dimensions for wheel building.

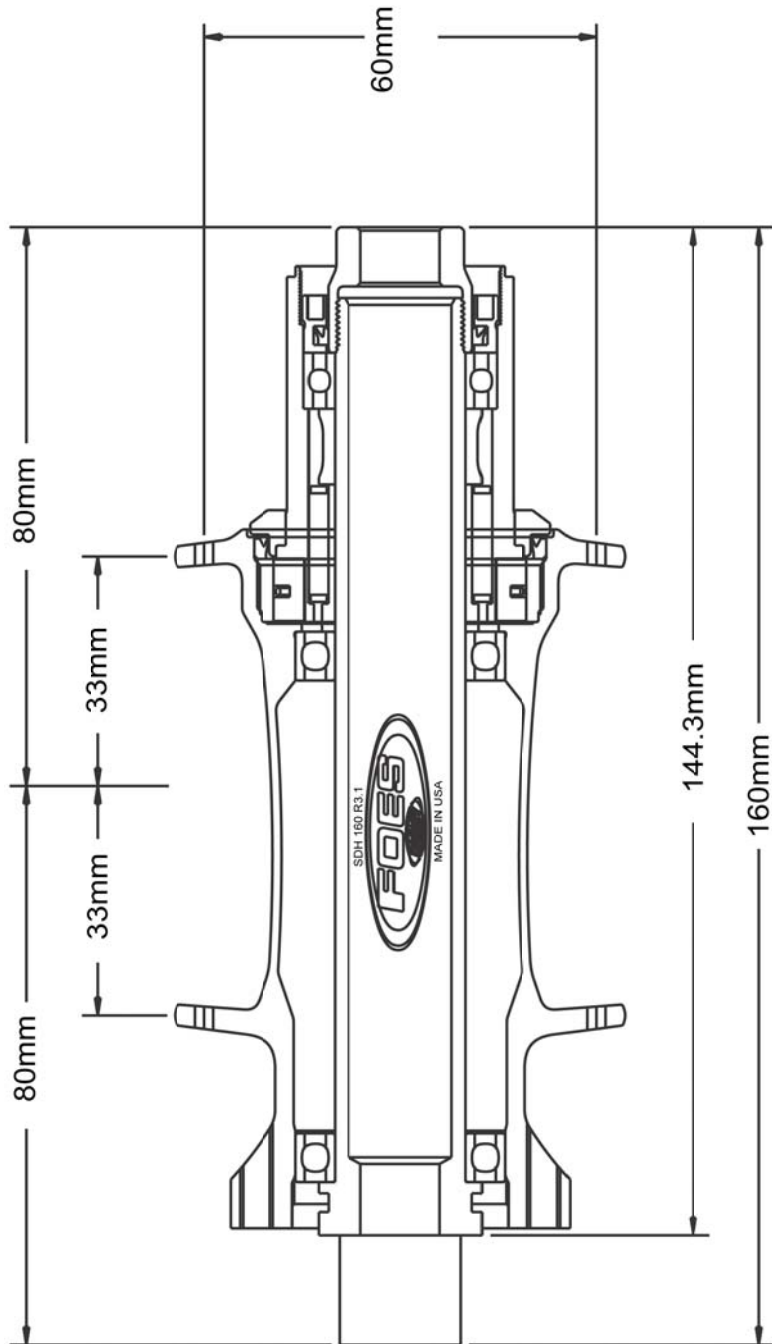

Adjusting Rebound Damping

Located near the opposite end of the shock is the Rebound Adjustment Knob (Fig. 3). You will see an arrow marked "S" (slow) and "F" (fast). Moving the Rebound Adjustment Knob in the direction of "S" will slow down the rebound movement. Moving the Rebound Adjustment Knob in the direction of "F" will speed up the rebound movement. Total adjustment occurs in about 1 turn. Move in small increments. The XTD's rebound speed is designed to be slow at the top and fast in the middle to bottom. It would be normal for the XTD to be returning (rebounding) slower than a standard shock during the last 1/2" of stroke. This is by design. Even though it may feel slower than what you are used to, at this point it will be fast enough in mid-stroke. Run rebound as fast as you can be comfortable with. You should be able to feel it slowing at the top.

The XTD shock isn't merely closing off a bypass hole in the main shaft, as do most other standard shocks. The XTD actually preloads the rebound plate, simulating a thicker or more resistant plate. To simulate this adjustment on standard shocks, you would have to completely depressurize & disassemble the shock to change the valve plate/stack.

TROUBLESHOOTING & OTHER TIPS

The XTD shock may feel a bit sticky for the first few rides until it breaks in. Use a light fork oil on the main shaft as often as needed. This will help keep the seal in the seal head saturated and this will minimize sticking and promote shock life. Make sure to wipe off excess after cycling the shaft as to not attract dirt.

Any sign of oil leakage is BAD! If something is going wrong internally, oil will leak out from the Rebound Adjustment Knob area. If you are seeing oil in this area and you are sure it is not the oil you lubed the shaft with (which would run out through the hole in the lower spring cap in the same area), internal failure has occurred.
DO NOT CONTINUE TO USE THE UNIT-RETURN IT FOR SERVICE!

Directly below the Ramping Adjustment Knob you will see the **CURNUTT** Sticker on the shock body. This sticker should be centered below the Ramping Adjustment Knob. If it is not centered, this would indicate that the shock body is loosening from the end cap. If this occurs turn the shock body clockwise until tight and sticker is again centered below the Ramping Adjustment Knob.

Make sure your pump is working properly. Put in 75 psi. Remove pump and re-install. Pressure drop should be about 15 psi. Gauge should read about 60 psi. This is normal and indicates no leakage. The 15 psi drop occurs because of the added volume necessary to cause the pump to read.

Setting and Adjusting Compensator Chamber pressure

As noted above, **there are a total of four turns of adjustment available on the Ramping Adjustment Knob**. When readjusting, **IF THERE IS ANY DOUBT WHERE THE ADJUSTMENT IS SET, TURN KNOB CLOCKWISE UNTIL IT STOPS AND BACK OFF AS NECESSARY, TO A MAXIMUM OF FOUR COUNTERCLOCKWISE REVOLUTIONS. REMEMBER, DO NOT FORCE PAST FOUR TURNS.**

The Ramping Adjustment Knob controls how stiff the shock gets during the last 30% of the total stroke.

If at 75 psi you are happy with the overall ride and sensitivity but are never using all of the travel, back the Ramping Adjustment Knob out 1 turn at a time. This will allow the XTD unit to use more of the stroke.

If at 75 psi (with correct sag) you are bottoming out, turning the Ramping Adjustment Knob in 1 turn at a time will minimize this.

Lower pressure will increase sensitivity to small impact forces.
NEVER GO BELOW 65 PSI

As you experiment with lower pressures, expect to adjust the Ramping Adjustment Knob clockwise to prevent bottoming. If you are running 65 psi (the minimum recommended) and occasionally bottom, going to 60 psi (not recommended) will result in serious bottoming unless Ramping Adjustment Knob is turned clockwise as pressure is reduced.

Higher pressures will result in improved pedaling efficiency (anti-bob). DON'T MISTAKE THIS FOR STICTION-It is SUPPOSED to ignore small bump or rider inputs. This is what makes "anti-bob" possible.

WARNING: EXCEEDING 100 PSI COULD RESULT IN FAILURE! Don't do it!

Once you find an acceptable setting, never think this is the final adjustment. Some courses/terrain may have more pedaling sections (higher pressure), some may have more "chatter bumps" (lower pressure), some may have excessive big hits & landings (higher pressure and more ramp). Consider the Curnutt XTD shock and adjustments a tool easily customized to meet your needs.

Foes Fabrications, Inc. (Foes) DBA Foes Racing, a California corporation located at 62 N. Sierra Madre Blvd., Pasadena, California 91107, makes the following Limited Warranty concerning Foes frames & forks:

Limited Warranty

LIMITED TWO YEAR WARRANTY ON DHS MONO SUSPENSION FRAMES

Foes warrants to the original owner that each new DHS Mono bicycle frame is free of defects in material and workmanship for a period of two years from the date of the original purchase to the original owner. Curnutt shocks are covered under warranty by Foes Racing for one year. Fox Racing Shox are covered under warranty by Fox Racing Shox for a period of one year. Foes Racing will not warranty or repair your Fox Shox.

This limited warranty does not apply to paint/finish or any other parts attached to the bicycle including forks, drive train, brakes, seat, seatpost, handlebar, stem or wheels. Paint/finish, stickers, and other parts attached to your Foes bicycle are covered under the limited one year warranty.

The original owner shall pay all labor and transportation charges associated with the repair or replacement of all parts under this warranty. Even if something is covered under warranty by Foes Racing, Foes Racing will not pay any transportation charges!

WHAT IS NOT COVERED

Failure due to accident, abuse, neglect, normal wear, improper assembly, improper fit, use of **DUAL CROWN FORKS with 9" or more of travel**, poor maintenance, maintenance by other than an authorized Foes Dealer or use of parts inconsistent with the use originally intended for the bicycle as sold are not covered by this warranty. What is the originally intended use?? Riding in a consistent, smooth manner in an approved location for bicycles with both wheel on the ground. Riding in a manner other than that, jumping, dropping to flat ground, improper maintenance, no maintenance **VOIDS** the warranty.

WHY IT'S NOT COVERED

Lets be for real here. If you drive any vehicle, truck, motorcycle, or airplane, and crash it, the manufacture is **NOT** going to replace it or repair it unless the product was defective and caused the crash and or accident.

If you bought this bike because you want to race, jump, ride ramps or vert, ride in severe conditions, ride in any type of competitive event, all the same applies! If you damage a part riding in this manner, consider the damaged part an expense of your riding style and plan to buy a replacement.

WHAT FOES WILL DO UNDER THE WARRANTY

Foes will replace or repair any part that is determined by Foes to be covered by this warranty. This limited warranty is made **ONLY** to the original owner and is not transferable. All claims must be made through an authorized Foes dealer and must be accompanied by the original bill of sale or proof of purchase that identifies the bicycle or frame by the serial number. The original owner is responsible for this and any and all labor and transportation charges associated with the warranty repair or replacement of all parts, even if Foes determines that it is under warranty.

WHAT IF YOUR FRAME IS NOT COVERED UNDER THE WARRANTY

If the warranty claim on your Foes frame is determined to be invalid, Foes Racing will offer a replacement frame/swingarm/part of at least equal value at a reduced price. This transaction will be offered only through an authorized Foes dealer and under the following conditions; frame has been registered with Foes Racing, frame is property of original purchaser, owner provides a valid sales receipt. This crash replacement is only available to the original owner and for a time period of three years from the original purchase date. The replacement frame must be assembled by an authorized Foes dealer to maintain the Foes warranty. All freight charges associated are the responsibility of the original owner.

ALL FOES FRAMES SHOULD BE INSPECTED PERIODICALLY BY A FOES DEALER

We cannot stress enough, building a pro level frame is not an endeavor recommended for home mechanics. Special tools and skills are a must, and the dealer can answer 99% of all questions related to the complete build of a high-end frame. Due to this fact, this manual covers only basic information.

USEFUL PRODUCT LIFE CYCLE

Every Foes frame and fork has a useful product life cycle. The length of that useful product life cycle will vary with the construction and materials of the frame or fork, the maintenance and care the frame or fork receives over its useful product life cycle, and the type and amount of use the frame or fork is subject to. Uses in competitive events, trick riding, ramp riding, jumping, aggressive riding, riding on severe terrain, riding in severe climates, riding with heavy loads, commercial activities and other types of non-standard use can dramatically shorten the useful life cycle of a Foes frame or fork. Any one or a combination of these conditions may result in an unpredictable failure of a Foes frame or fork that would not be covered by this warranty. **ALL FOES FRAMES AND FORKS SHOULD BE PERIODICALLY CHECKED BY A RETAIL BICYCLE OUTLET OR A FOES DEALER**, for indicators of stress and/or potential failure, including cracks, deformation, corrosion, paint peeling, dents, and any other indicators of potential problems, inappropriate use or abuse. These are important safety checks and may be very important to help prevent accidents, bodily injury to the rider and shortened life cycle of the Foes Frame or Fork. **THIS IS AN INTEGRATED AND FINAL STATEMENT OF FOES LIMITED WARRANTY. FOES DOES NOT AUTHORIZE OR ALLOW ANYONE, INCLUDING FOES DEALERS OR RETAIL BICYCLE OUTLETS, TO EXTEND ANY OTHER WARRANTIES, EXPRESSED OR IMPLIED, FOR FOES. NO OTHER REPRESENTATION, AND NO STATEMENT OF ANYONE BUT FOES, INCLUDING A DEMONSTRATION OF ANY KIND BY ANYONE SHALL CREATE ANY WARRANTY REGARDING THIS FRAME OR FORK. ALL OF THE REMEDIES AVAILABLE TO THE ORIGINAL OWNER ARE STATED HEREIN. IT IS AGREED THAT FOES LIABILITY UNDER THIS LIMITED WARRANTY SHALL BE NO GREATER THAN THE ORIGINAL PURCHASE PRICE AND IN NO EVENT SHALL FOES BE LIABLE FOR INCIDENTAL OR CONSEQUENTIAL DAMAGES.**

DISCLAIMER

All other remedies, obligations, liabilities, rights, warranties, expressed or implied, arising from law or otherwise, including but not limited to, any claimed implied warranty of merchantability, any claimed implied warranty arising from course of performance, course of dealing or usage of trade, and any claimed implied warranty of fitness, are disclaimed by Foes and waived by the original owner. Some states, jurisdictions, countries, provinces, do not allow some or all of the limitations set herein, or the exclusion or limitation of incidental or consequential damages. If any provision is found enforceable, only that provision shall be stricken and all others shall apply. This limited warranty does provide the original owner with certain legal rights and recourse and the original owner may possess other rights or recourse, depending on the state, jurisdiction, country or province.

WARNING: BICYCLE RIDING CAN BE HAZARDOUS TO YOUR HEALTH, EVEN FATAL! BE SURE TO ALWAYS WEAR A HELMET AND PROPER PROTECTIVE CLOTHING.

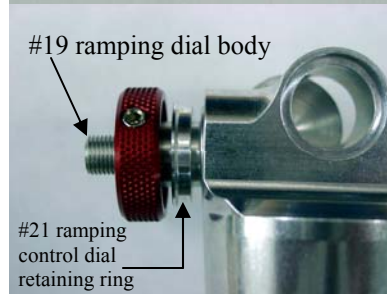

This is the compression assembly. Turning this piece past 4 turns will blow the piece out of the shock. There is no cir-clip. When the knob is turned past 4 turns, the ramping control dial retaining ring(#21) will be pushed out by the ramping dial body(#19) The ramping control dial(#20)(Red) should always be flush with the last shoulder of the ramping dial body(#19) just under the threads of the air valve.

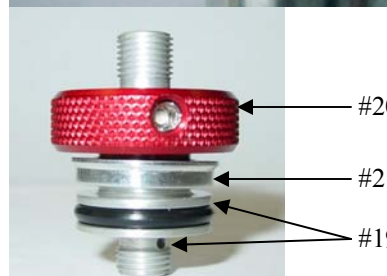

All Foes models use a swinglink to laterally stiffen the area between the swingarm and main frame, allowing the frame to be much more responsive when hammering out of the saddle. Each swinglink is CNC machined and assembled with cartridge bearings. Swinglink o'haul kits are available for each model and come with; bearings, inner spacers, and bolts. Extracting and pressing

Bearing and SwingLink Info



Cartridge Bearing Info:

- DHS Mono SwingLink: 698 2RS (Quantity of 6)
- DHS Mono Main Pivot: B541/F (Quantity of 4, 2per side + inner spacer)
- DHS Mono Floating Brake Arm: 6903RS (Quantity of 2)

Recommended Base Set-up

*Set Ramping Adjustment knob (Fig. 1) at two turns out (there is a total of four revolutions; turn knob clockwise all the way in until it stops & then back it off two complete revolutions). **VERY IMPORTANT- DO NOT FORCE KNOB TO BACK OUT MORE THAN FOUR COMPLETE REVOLUTIONS-DOING SO COULD CAUSE LEAKAGE/FAILURE. THERE IS NO CIR-CLIP FOR THIS KNOB, IT WILL BLOW OUT IF TURNED PAST 4 TURNS FROM COMPLETE BOTTOM!! EVERYSHOCK IS HANDBUILT AND TESTED BEFORE IT LEAVES FOES. FOES WILL NOT WARRANTY VALVES THAT BLOW OUT DUE TO RIDER ERROR. THE VALVE CAN ONLY BE REPLACED BY FOES AND SO IT MUST BE RETURNED AND THERE IS A \$20.00 FEE PLUS SHIPPING.**

*Use Schrader valve (Fig. 2) to pressurize to 75 psi (use a quality high pressure shock pump intended for this application-obtainable at decent bike shops)

*Set total sag. Shock should have at least 1" of sag when the riders full weight with gear on. With the adjustable rod end on the 2004 DHS Mono shock the eye to eye length is different by the amount the rod end is adjusted in or out. The best way is to have someone help support the rider check this measurement while the rider is balanced upon the bike. This operation must be performed on a level surface (no incline!!!). You should use the preload adjuster (Fig. 4) only as a spring holder-**excessive preload is absolutely not recommended.** Once set, put a mark on the preload adjuster and another on the shock body to make sure it isn't backing off after riding. Check sag weekly!

To determine the correct spring rate:

With the shock fully extended, loosen preload adjuster until it no longer touches the spring. Tighten until preload adjuster first touches the spring. Using a felt tip marker, put a mark on the spring, and another on the shock body. This will help you determine EXACTLY when one full turn of the preload adjuster has been made. If LESS than one full turn of the preload adjuster is used to obtain the proper 1" of sag at the shock, the spring rate is too heavy, and the next softer spring should be used. If MORE than four full turns are needed to achieve the proper sag, the spring rate is too light, and the next firmer spring should be used. NEVER USE MORE THAN FIVE FULL TURNS OF SPRING PRELOAD. Warranty will not be granted to Curnutt Shocks and or the springs if EXCESSIVE PRELOAD was being used or if the SHOCK has been ridden with the wrong spring rate (under sprung). A full range of springs is available in steel or titanium from Foes Dealers only, Foes Fabrications does not sell consumer direct, you must obtain parts from Authorized Foes Dealers.

Optimum pressure range is 65 psi (minimum) to 100 psi (maximum). Note: CHECK PRESSURE BEFORE EVERY RIDE! REMEMBER: NO PRESSURE= NO DAMPING

WARNING: NEVER EXCEED 100PSI. EXCEEDING 100 PSI COULD RESULT IN FAILURE!

General Set-Up

SHOCK SET-UP

ALERT, you will damage your bike frame and your shock if you do not correctly set-up your rear suspension. If you bottom out your shock on a regular basis, you are under sprung and will damage your frame and shock. Bottoming your shock on a consistent basis is considered by Foes to be improper care of your bicycle frame and shock and will VOID both and all warranties. If you are running an air sprung shock then you need to increase air pressure...if you are running a coil over shock, i.e.. Curnutt, then you need to increase your spring rate.

Foes Frame Specs for Building

- **Bottom Bracket width:** 68mm shell
- **Bottom Bracket Axle length:** determined by crank choice.
- **Seat Post Diameter:** 31.6mm
- **Head Tube Diameter:** 1 1/8" headset only
- **Fork type/length:** The DHS Mono was designed around and to work best with a 8.5" travel dual crown fork with an axle to crown length of 559mm.
- **Front Derailleur:** CANNOT TAKE FRONT DERAILLEUR
- **Chain Guide System:** The DHS Mono is made to accept the Foes Chain Guide Only
- **Rear Hub Spacing:** 12mm through axle with 160mm Spaced Hadley Hub (comes with frame)
- **Rear Tire Max Size:** The DHS Mono is made to accept up to a 2.7" width tire. This fit depends on rim type being used, tire manufacture being used, and a properly dished wheel
- **Disc Brake:** The Foes DHS Mono accepts only 8" rotors. The frame is sent with either an I.S. mount or a Post Mount Style floating arm. The DHS Mono can only use a floating rear caliper, this system comes standard on all DHS Mono and is made to use 8" rotors with no adapters. Use of Foes Floating Brake Set-up offers an advantage over a ridge mounted caliper on the swingarm. The floating set-up allows the rear brake and the rear suspension to act independently, thus allowing your rear suspension to work on its own regardless of braking effort and also keeping the rear wheel to the ground more, than a conventional ridged mounted caliper.



General Set-Up Continued

Good Rider Bicycle Maintenance

- Keep your bike clean. Riding a dirty bike will cause all your bearings, contact point, finish, moving parts to faded away faster than the setting sun. Keeping your bike clean will also give you that satisfied feeling of taking care of your investment in a high quality hand crafted frame...not to mention it probably set you back at least \$4000.00 so why wouldn't you maintain your bicycle...common sense!
- Keep your bike clean and lubricated
- Record your serial number and keep all receipts. It's also a good idea to take pictures of your bike and its components and give them to your insurance company along with proof of purchase. It's also a GREAT idea to register your frame and shock with Foes racing, otherwise you risk not getting any type of warranty service if it's ever needed.
- Periodically check all bolts and fasteners. Do not over tighten anything as this too will VOID questionable warranties. Make sure to also check your frame at all welds and tube junctions for cracks and any damage, Aluminum has a limited life, inspect the frame in a well lit area and inspect well!
- Inspect your frame and its parts before every ride and after crashes, check for proper air pressure in both your tires and suspension.
- Keep the shaft of your rear suspension clean of dirt and crud, and wipe it off after every ride.

Minimum/Maximum Seat Post Insertion

- In addition to the minimum insertion mark on most seat posts, you must follow the following recommendations for seat post insertion.

Minimum Insertion: A 31.6mm seat post must be inserted a minimum of 4" into the seat tube of the frame. Anything less than this can cause damage to your frame and will not be covered under warranty.

Maximum Insertion: You will damage your shock if you insert your seat post too far. This is an obvious acknowledgement and if you properly inspect and set up your bike should be a no brainer. It may be necessary to cut your seat post shorter to achieve your desired seat post height.

Replaceable Rear Derailleur Hanger

The 2004-2005 Foes DHS Mono is equipped with a replaceable derailleur hanger. This part is installed as a safety feature as well as a convenience to you, the owner. It is not uncommon for foreign objects, such as sticks, stones, and other debris to bend your hanger. A bent hanger can also occur from shifting hard under load and or transporting your bicycle. It is always good to have spare hangers on a ride as they are made to bend without much force in an effort to save you money and your frame! Derailleur hangers are available from your Foes dealer and are not covered under any type of warranty. The part number for the Foes DHS Mono replaceable derailleur hanger is **HA01**

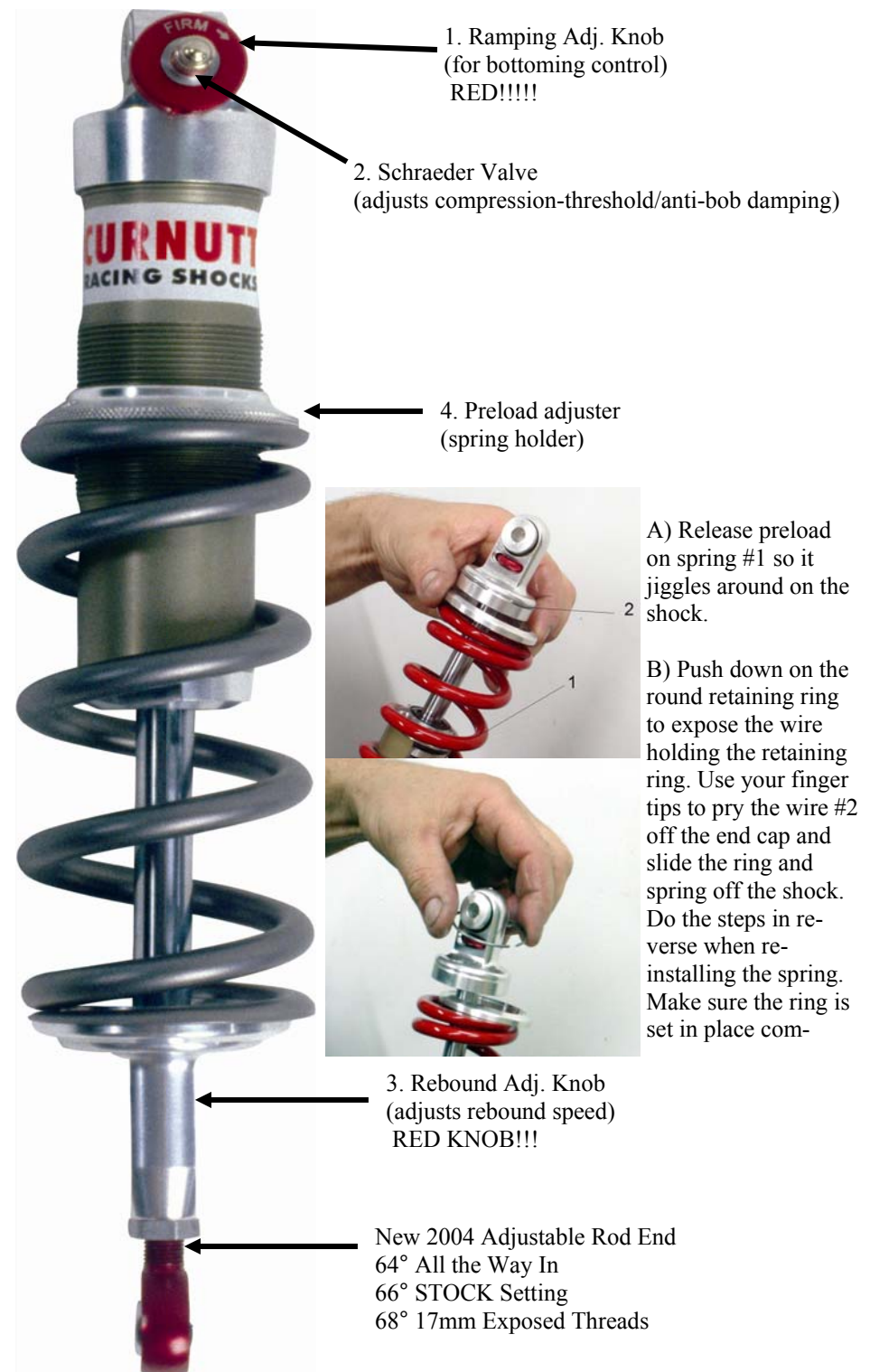

CURNUTT

XTD-SHOCK: SET-UP

Congratulations on purchasing the finest rear shock ever produced for the mountain bike industry. The XTD shock is the result of four years' testing by the Foes Mountain Bike Racing Team and Curnutt Shocks. The XTD's first full season of use at National and World Cup levels resulted in a NORBA National Champion and a Jr. World Champion. Curnutt introduced "Position Sensitive" or "Platform-damped" technology to the bicycle industry, and has sent a serious wake-up call to the "big boys" in the bicycle suspension field. We highly recommend you take the time to fully read and perform the following set-up instructions.

Warranty: Foes Racing will not warranty or perform warranty service for shocks that have been ridden under sprung, ridden with excessive preload, any of the above stated troubleshooting, and or what Foes Fabrications deems to be rider error due to improper use and or maintenance. Meaning this, if you take care of your bike and perform routine maintenance and inspections of your bicycle frame, parts and accessories you will notice problems, like the shock bottoming out consistently. Riders who ride Curnutt Shocks that are under sprung, bottoming out consistently, or overall appear to not be in proper condition, and or any of the above stated issues will not receive warranty status upon inspec-

2004-2005 Foes DHS Mono Frame Geometry

General Sizing Guidelines by Rider Height

Small - Riders up to 5'6" (168cm)

Medium - Riders 5'6" to 6' (168cm to 183cm)

Large - Riders 6' and up (183cm+)

A - Size

C - Head Tube Angle (degrees)

E - Bottom Bracket Height (inches)

G - Estimated Wheelbase (inches)

I - Top Tube - Effective (inches)

K - Rear Wheel Travel (inches)

B - Head Tube Length (inches)

D - Seat Tube Angle (degrees)

F - Chainstay Length (inches)

H - Top Tube - Actual (inches)

J - Seatpost Diameter (mm)

A	B	C	D	E	F	G	H	I	J	K
S 17.2	4.5	66.25	56.5	14.7	17.8	44	19.3	21.8	31.6	10
M 18.5	4.5	66.25	56.5	14.7	17.8	45	20.5	23	31.6	10
L 19.7	5	66.25	56.5	14.7	17.8	45.8	21.6	23.8	31.6	10

Adjustments

Your Foes DHS Mono is a single rear wheel travel setting only at 10" which is intended to be matched with a 8.5" travel dual crown fork with a center of axle to lower crown length of 559mm. Going above this travel or below this travel will change the head angle of the frame and in Foes' opinion is not optimal for the frame design. The DHS Mono also has an adjustable rod end in the shock. This adjustments allows the rider to change the bottom bracket height by about 1/4" and adjust the head angle about +/- 2degrees. Please follow the instructions at the front of the Curnutt section in this manual to change the rod end setting on the DHS Mono shock.

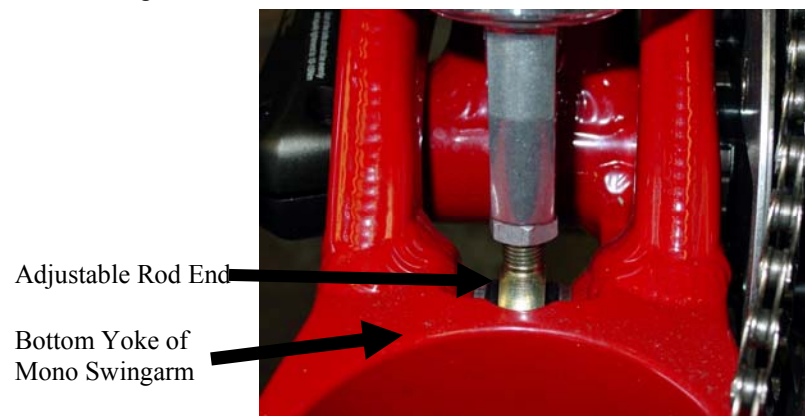

DHS Mono Floating Disc Brake Info



Rear View of Floating Brake

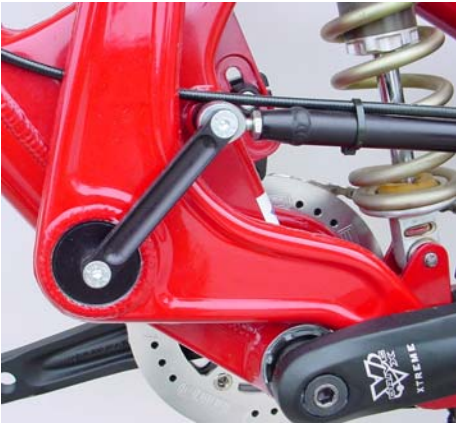

Front View of Floating Brake Rod

Foes DHS Mono has 160mm rear hub spacing with a floating brake assembly only mounted inside the swingarm. Each DHS Mono comes with a rear Hub and floating disc brake set-up axle and dropout. The floating mount is made for 8" rotors only and can be set-up with either an I.S. mount or a post mount style brake using no manufac-



I.S. 8" Only

Post Mount 8"

Each frame includes the floating brake setup, you the customer specify I.S. or Post Mount caliper mount.

Foes DHS Mono Chain Guide System

The Foes DHS Mono can only take a single chain-ring, and thus only accepts a chain guide made by Foes for the DHS Mono. Because of the swingarm design no other chain guide system will fit the DHS Mono. The chain guide system is NOT included with the DHS Mono and is available from your Foes dealer only. It is available in 5bolt WC, 4bolt WC, 4bolt SL and as upper and lower arms only without chain plates.

Foes complete Chain Guide

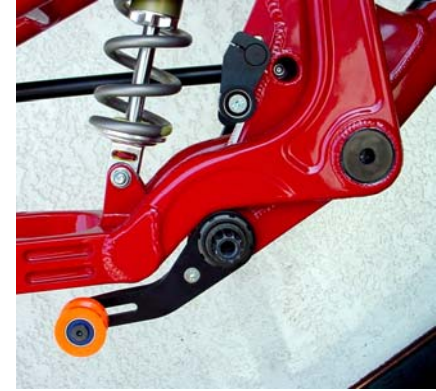

Upper & Lower Chain Guide Arms Mounted
Lower arm mounts with bottom bracket and a single bolt to a tab welded to the underside of the bb shell. The upper arm mounts to a slotted piece on the main frame. Refer to the picture below for proper setup.

Make sure you set-up your chain guide correctly!! Incorrect setup will result in a cracked frame and a ruined swingarm, due to the upper mount hitting the swingarm monoque piece. Foes will not warranty any frame damage due to improper setup. For more detailed info and pictures please refer to the Foes website under tech help.

